

## INSTALLATION INSTRUCTIONS

### Removal of Fusible Link on Fire Dampers

#### Closing Damper to Perform Periodic Maintenance

1. Ensure that you are working from the “K-side” of the damper as noted in Figure 1. Failure to do so could result in increased difficulty in reopening the damper. If the K-side is not accessible refer to IOM part number 459019 (Latch Release Tool).
2. Support blade stack (Figure 2, item 5) on both sides of the fusible link (Figure 2, item 4). Note that some damper models are supplied with high tension closure-springs. Failure to support the blade stack once the link has been removed will result in rapid closure of the blades.
3. Bend metal straps so that they are straight. Remove fusible link from straps.
4. Support blade stack with hands and slowly lower the blade stack to the bottom of the damper frame.
5. Inspect fusible link for cracks or corrosion. If necessary replace with link of the same model and temperature rating.

#### Resetting Damper to Open Position

1. If you haven’t already done so, bend the metal straps (item 3) so that they are straight.
2. Lift blade stack to the top of the damper frame such that the blades fold up like an accordion. Support blade stack (Figure 2, item 5) on both sides of the fusible link (Figure 2, item 4). Note that some damper models are supplied with high tension closure-springs. Failure to support the blade stack will result in rapid closure of the blades.
3. Slide the replacement fusible link on to the metal straps. Fusible link must be installed with temperature rating facing outward.
4. Bend the metal straps up to hold the fusible link in place.
5. Remove any temporary supports used to hold blade stack at the top of the damper frame.

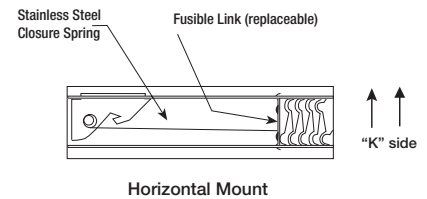
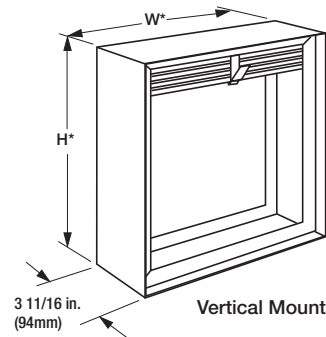
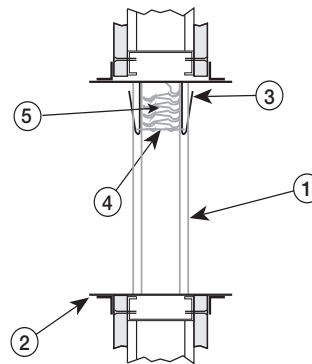

Figure 1



Item #	Description
1	Damper
2	Sleeve
3	Metal strap
4	Fusible link
5	Blade Stack

Side cross-section view of  
Curtain Fire Damper in wall

Figure 2

## Replacing fusible link on a combination fire smoke damper:

- 1) If fail closed, disconnect power and/or air pressure from damper. If fail open, apply power and/or air pressure to damper. Damper should be in the full closed position.
- 2) Remove and discard the existing retaining clips (Figure 3, item 1) and fusible link (Figure 3, item 2).
- 3) Install replacement fusible link as shown in the diagram (temperature rating facing outward). The crankarm secured with a bolt may require some minor rotation to align link with pins.
- 4) Install retaining clips in the groove of each of the pins holding the fusible link.
- 5) Reconnect power.

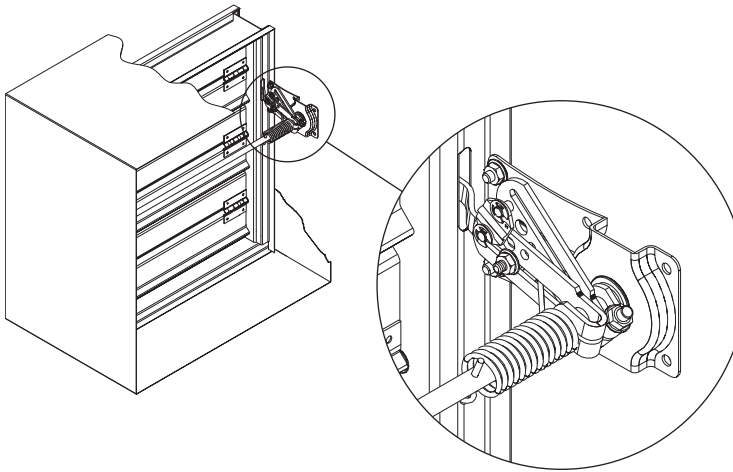

Note: When replacing fusible link, make sure it is the same temperature. If a different temperature, consult factory.

Important!

Fusible link must be put on with temperature rating facing outward as shown

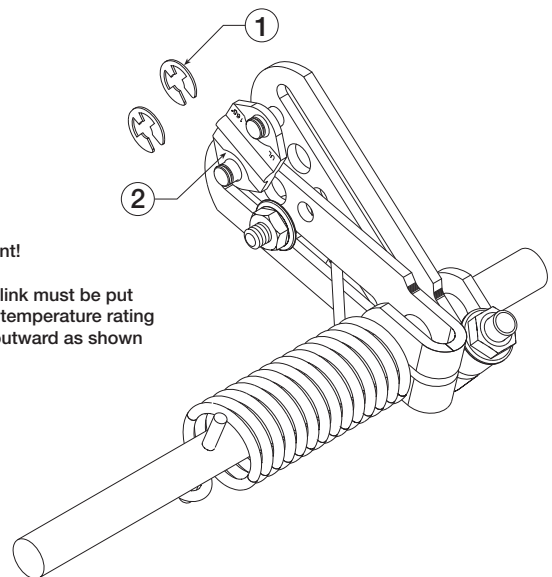
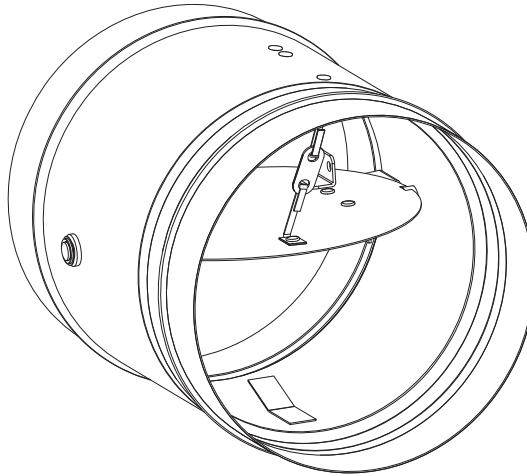

Figure 3

Item #	Description
1	Retaining clips
2	Fusible link

## Replacing fusible link on a round fire or combination fire smoke damper:

- 1) Bend metal straps so they are straight. Remove separated fusible link.
- 2) Hold blade latch against the frame and rotate blade to full-open position.
- 3) Slide the replacement fusible link on to the metal straps. Fusible link must be installed with temperature rating facing outward.
- 4) Bend the metal straps up to hold the fusible link in place.
- 5) Reconnect power (combination fire smoke damper only).



## Our Commitment

*As a result of our commitment to continuous improvement, Greenheck reserves the right to change specifications without notice.*

Product warranties can be found online at [Greenheck.com](http://Greenheck.com), either on the specific product page or in the literature section of the website at [Greenheck.com/Resources/Library/Literature](http://Greenheck.com/Resources/Library/Literature).

