



Model DFDAF-310

Multi-blade Fire Damper

Steel Airfoil Blades

UL555 1½ Hour Fire Resistance Rating

Application

Model DFDAF-310 is a dynamic rated multi-blade fire damper with airfoil style blades for use in walls, floors, and partitions with fire resistance rating of less than 3 hours. The DFDAF-310 is qualified to 4,000 fpm (20.3 m/s) and 8 in. wg (2 kPa) for dynamic closure in emergency fire situations. Model DFDAF-310 may be installed vertically (with blades running horizontal) or horizontally and is rated for airflow in either directions.

Ratings

UL 555 Fire Resistance Rating

Fire Rating: 1½ Hour

Dynamic Closure Rating: Actual ratings are size dependent

Velocity: Up to 4,000 fpm (20.3 m/s) on sizes up to 32 in. x 50 in. (813mm x 1270mm); 2,000 fpm (10.2 m/s) on sizes greater than 32 in. x 50 in. (813mm x 1270mm)

Pressure: Up to 8 in. wg (2 kPa)



W & H dimensions furnished approximately ¼ in. (6 mm) undersize.

(Add sleeve thickness for overall sleeved damper dimension)

Construction	Standard	Optional
Frame Material	Galvanized steel	-
Frame Material Thickness	16 ga. (1.5mm)	-
Frame Type	5 in. x 1 in. (127mm x 25mm) hat channel	-
Blade Material	Galvanized steel	-
Blade Material Thickness	14 ga. (2mm) equivalent	-
Blade Type	Double skin airfoil	-
Linkage	Plated steel out of airstream, concealed in jamb	316SS
Axle Bearings	316SS	-
Axle Material	Plated steel	316SS
Jamb Seals	Stainless Steel	-
Closure Device	Fusible link	-
Closure Temperature	165°F (74°C)	212°F (100°C), 286°F (141°C), 350°F (177°C)
Actuator	Manual quadrant	-

Model DFDAF-310 meets the requirements for fire dampers established by:

National Fire Protection Association
NFPA Standards 80, 90A & 101

IBC International Building Codes
CSFM California State Fire Marshal
Fire Damper Listing (#3225-0981:103)



See complete marking on product.

UL 555 Classification
R13317

Features

- Frames are constructed with reinforced corners. Low profile head and sill are used on sizes less than 17 in. (432mm) high.
- Blades are double skin airfoil shape of galvanized steel with full length structural reinforcement.

W x H	Minimum Size	Maximum Size		
		Single Section	Multi-Section	
			2000 fpm (10.2 m/s)	4000 fpm (20.3 m/s)
Inches	8 x 6	32 x 50	128 x 100 (V) or 144 x 96 (H)	32 x 50
mm	203 x 152	813 x 1270	3251 x 2540 or 3658 x 2438	813 x 1270

Options available for DFDAF-310:

- Extra Fusible Links
- Factory mounted accessories
 - Quick connect breakaway connections
 - Access doors
- Flanges
- Grille Tabs
- OCI (Open Closed Indication switches): Units will be supplied with one OCI per row of damper sections
- POC retaining angles
- Security bars
- Sealed transition and sleeves
- Sleeves
- Smoke Detector
- Test Switch (GTS-4)
- Transitions (R, C, O)

Pressure Drop Data

This pressure drop testing was conducted in accordance with AMCA Standard 500-D using the three configurations shown. All data has been corrected to represent standard air at a density of .075 lb/ft³(1.201 kg/m³).

Actual pressure drop found in any HVAC system is a combination of many factors. This pressure drop information along with an analysis of other system influences should be used to estimate actual pressure losses for a damper installed in a given HVAC system.

AMCA Test Figures

Figure 5.3 Illustrates a fully ducted damper. This configuration has the lowest pressure drop of the three test configurations because entrance and exit losses are minimized by straight duct runs upstream and downstream of the damper.

Figure 5.2 Illustrates a ducted damper exhausting air into an open area. This configuration has a lower pressure drop than Figure 5.5 because entrance losses are minimized by a straight duct run upstream of the damper.

Figure 5.5 Illustrates a plenum mounted damper. This configuration has the highest pressure drop because of extremely high entrance and exit losses due to the sudden changes of area in the system.

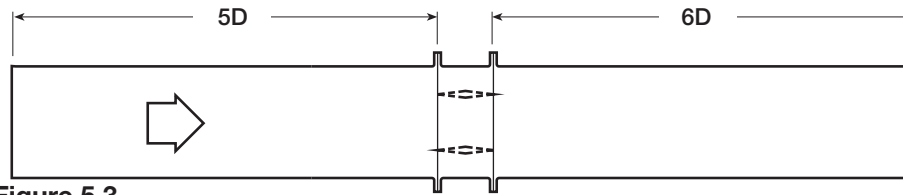

Figure 5.3

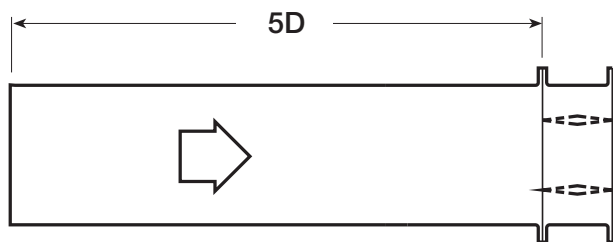

Figure 5.2

$$D = \sqrt{\frac{4(W)(H)}{3.14}}$$

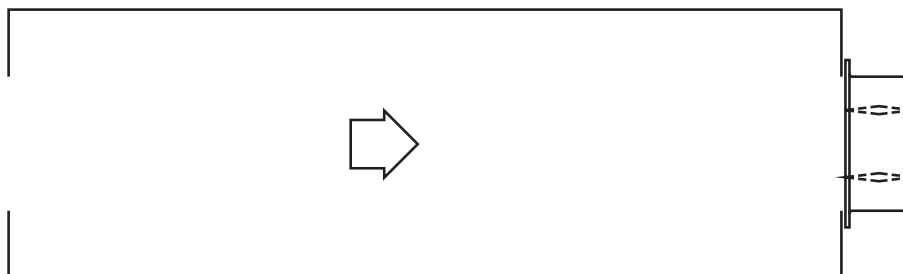
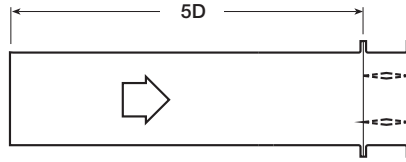

Figure 5.5

AMCA Figure 5.2



12 in. x 12 in. (305mm x 305mm)

Velocity (fpm)	Pressure Drop (in. wg)
500	0.03
1000	0.12
1500	0.26
2000	0.46
2500	0.72
3000	1.04
3500	1.41
4000	1.84

24 in. x 24 in. (610mm x 610mm)

Velocity (fpm)	Pressure Drop (in. wg)
500	0.01
1000	0.06
1500	0.12
2000	0.22
2500	0.34
3000	0.49
3500	0.67
4000	0.87

36 in. x 36 in. (914mm x 914mm)

Velocity (fpm)	Pressure Drop (in. wg)
500	0.01
1000	0.06
1500	0.12
2000	0.22
2500	0.34
3000	0.49
3500	0.67
4000	0.88

12 in. X 48 in. (305mm x 1219mm)

Velocity (fpm)	Pressure Drop (in. wg)
500	0.01
1000	0.05
1500	0.12
2000	0.21
2500	0.33
3000	0.48
3500	0.65
4000	0.88

48 in. x 12 in. (1219mm x 305mm)

Velocity (fpm)	Pressure Drop (in. wg)
500	0.02
1000	0.08
1500	0.18
2000	0.33
2500	0.51
3000	0.74
3500	1.00
4000	1.31

AMCA Figure 5.3

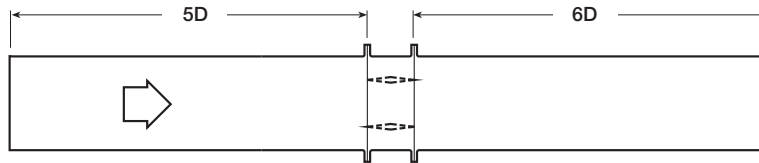

12 in. x 12 in. (305mm x 305mm)

Velocity (fpm)	Pressure Drop (in. wg)
500	0.01
1000	0.06
1500	0.13
2000	0.23
2500	0.37
3000	0.53
3500	0.73
4000	0.95

24 in. x 24 in. (610mm x 610mm)

Velocity (fpm)	Pressure Drop (in. wg)
500	0.01
1000	0.02
1500	0.06
2000	0.10
2500	0.16
3000	0.23
3500	0.32
4000	0.42

36 in. x 36 in. (914mm x 914mm)

Velocity (fpm)	Pressure Drop (in. wg)
500	0.01
1000	0.02
1500	0.05
2000	0.09
2500	0.14
3000	0.21
3500	0.29
4000	0.38

12 in. X 48 in. (305mm x 1219mm)

Velocity (fpm)	Pressure Drop (in. wg)
500	0.01
1000	0.02
1500	0.06
2000	0.10
2500	0.16
3000	0.24
3500	0.33
4000	0.43

48 in. x 12 in. (1219mm x 305mm)

Velocity (fpm)	Pressure Drop (in. wg)
500	0.01
1000	0.04
1500	0.10
2000	0.18
2500	0.29
3000	0.42
3500	0.57
4000	0.74

AMCA Figure 5.5

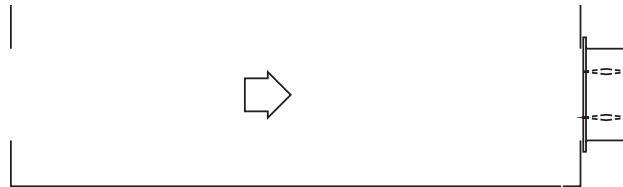

12 in. x 12 in. (305mm x 305mm)

Velocity (fpm)	Pressure Drop (in. wg)
500	0.04
1000	0.18
1500	0.42
2000	0.75
2500	1.17
3000	1.68
3500	2.29
4000	2.99

24 in. x 24 in. (610mm x 610mm)

Velocity (fpm)	Pressure Drop (in. wg)
500	0.03
1000	0.13
1500	0.29
2000	0.52
2500	0.81
3000	1.17
3500	1.60
4000	2.14

36 in. x 36 in. (914mm x 914mm)

Velocity (fpm)	Pressure Drop (in. wg)
500	0.03
1000	0.12
1500	0.27
2000	0.48
2500	0.75
3000	1.08
3500	1.48
4000	1.93

12 in. X 48 in. (305mm x 1219mm)

Velocity (fpm)	Pressure Drop (in. wg)
500	0.03
1000	0.12
1500	0.27
2000	0.49
2500	0.77
3000	1.11
3500	1.51
4000	1.97

48 in. x 12 in. (1219mm x 305mm)

Velocity (fpm)	Pressure Drop (in. wg)
500	0.03
1000	0.14
1500	0.32
2000	0.57
2500	0.89
3000	1.28
3500	1.75
4000	2.29



Greenheck Fan Corporation certifies that the model DFDAF-310 shown herein is licensed to bear the AMCA Seal. The ratings shown are based on tests and procedures performed in accordance with AMCA Publication 511 and comply with the requirements of the AMCA Certified Ratings Programs. The AMCA Certified Ratings Seal applies to air performance ratings only.

Damper Sizing Information

Dampers larger than maximum single section size are supplied as a factory assembly of two or more sections of equal size. The following figures show maximum damper section size and assembly configurations for multi-section dampers. Larger damper sizes may ship in multiple sections.

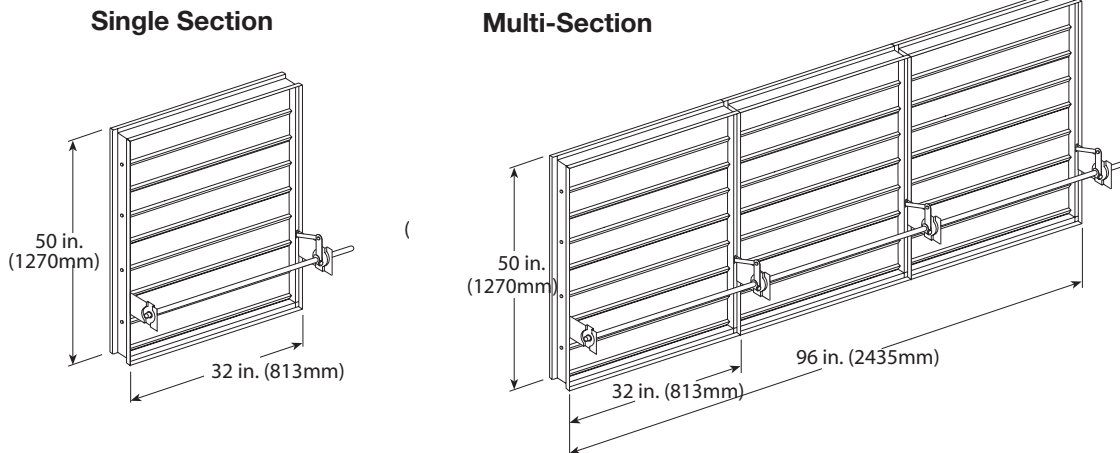

Damper Sleeve Dimensional Data

The drawings below and corresponding table show the position of the DFDAF-310 damper when mounted in a factory sleeve. The standard mounting locations provide enough space for the mounting of manual quadrant, controls and allow space for installation of retaining angles and duct connections.

The "A" dimension is the location of the damper mounted in a factory sleeve. The table below shows the Standard and Maximum "A" dimensions.

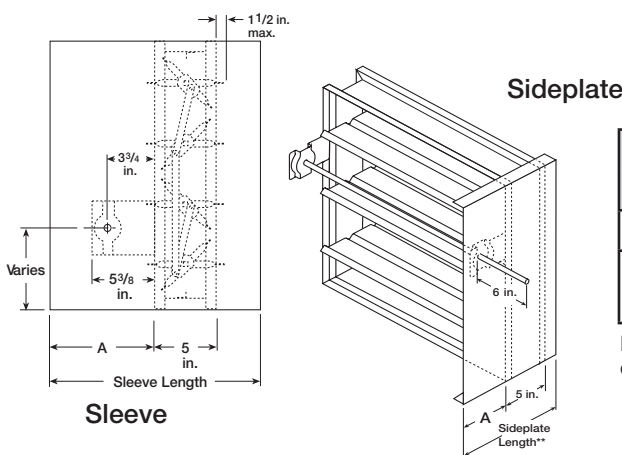

in. (mm)	"A" Dimension		
	Sleeve Std	Sleeve Max	Sideplate
All Dampers	7 3/16 in. (183)	16 (406)	6 3/16 (157)
When Height is 11 in. (279) or less with OCI	12 (305)	16 (406)	12 (305)

NOTE: Entire damper frame is not required to be installed within the wall. The damper blades, when closed should be contained within the wall.

Specifications

Fire Dampers meeting the following specifications shall be furnished and installed where shown on plans and/or as described in schedules. Dampers shall meet the requirements of the latest edition of NFPA 80, 90A and 101.

Dampers shall be tested, rated and labeled in accordance with the latest edition of UL Standard 555. Dampers shall have a UL 555 fire rating of 1 1/2 hours. Each damper shall be equipped with a heat responsive device which has been tested and approved for use with the damper assembly in accordance with UL 555. The heat responsive device shall have a temperature rating of (specifier select one of the following) 165°F (74°C), 212°F (100°C), 286°F (141°C), or 350°F (177°C).

Dampers shall be UL labeled for use in dynamic systems. The damper shall have a dynamic closure pressure rating of 4 in. wg (1 kPa) or 8 in. wg (2 kPa). UL 555 Dynamic Closure Ratings shall be qualified for airflow and pressure in either direction through the damper. UL ratings shall allow for mounting damper vertically (with blades running horizontal) or horizontally.

Damper actuator shall be manual quadrant. Manufacturer's submittal data shall indicate actuator space requirements around the damper.

Damper blades shall be 14 ga. (2mm) galvanized steel airfoil style. Blades shall be symmetrical relative to their axle pivot point, presenting identical resistance to airflow and operation in either direction through the damper (blades that are non-symmetrical relative to their axle pivot point or utilize blade stops larger than 1/2 in. (13mm) are unacceptable).

Damper frame shall be 16 ga. (1.5mm) galvanized steel formed into a structural hat channel shape with reinforced corners. Bearings shall be 316SS type rotating in extruded holes in the damper frame for maximum service. Axles shall be square and positively locked into the damper blade. Jamb seals shall be stainless steel compression type.

Testing and ratings to be in accordance with AMCA standard 500-D. Basis of design is Greenheck Model DFDAF-310.



Copyright © 2021 Greenheck Fan Corporation
DFDAF-310 Rev. 18 September 2021