

Refer to:

'Installation Instructions for FD, DFD, DFD X series and FD X series Curtain Fire Dampers' (Part #481324)

or

'Installation Instructions for FSD-xxx, DFD-xxx, & SSFSD-xxx series Combination Fire Smoke Dampers' (Part #481318)

or

'Installation Instructions for DFDR, FDR, and FSDR Round Fire and Combination Fire Smoke Dampers' (Part #481319)

or

'GFSD-xxx series Grille Access Out of Wall/Floor Combination Fire Smoke Dampers' (Part #472477)

or

'OFSD-xxx, ODFD-xxx, and OFD-xxx Out of Wall/Floor Combination Fire Smoke and Fire Dampers' (Part #461337) for additional details.

**FD, DFD,ODFD, and OFD Series
1½ Hour Curtain Fire Dampers and
FSD, OFSD and GFSD Series
1½ hour Combination Fire Smoke Dampers
Vertical Mount
DFDR, FDR, FSDR Series
1½ hour Round Fire and Combination Fire
Smoke Dampers and
Metal Stud Framing for Fire Dampers in
Cavity Shaftwall Partitions**



Notes

1. Gypsum panels must be screwed 12 in. (305 mm) on center maximum to all stud and runner flanges surrounding opening. (See **Figure 1** and **Figure 2** for Opening Preparation Details).

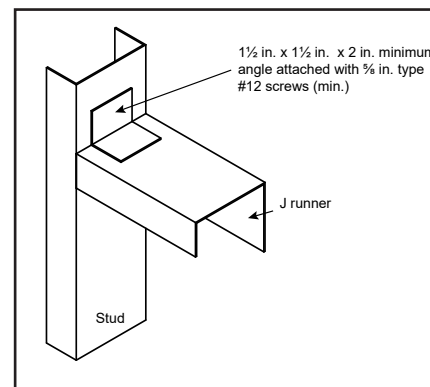
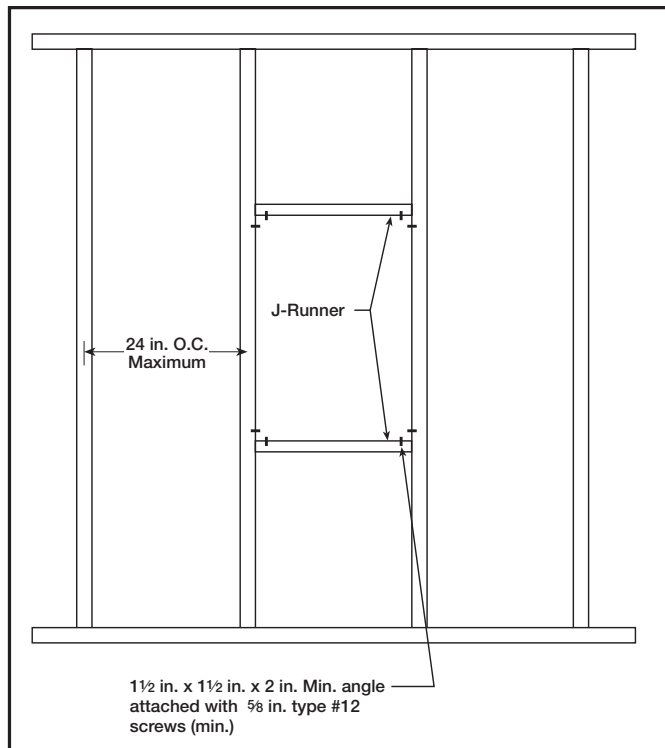

Figure 1: Opening Preparation Detail

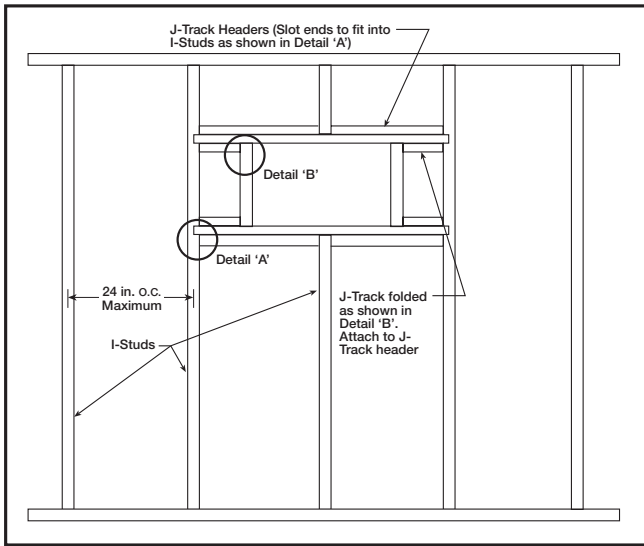
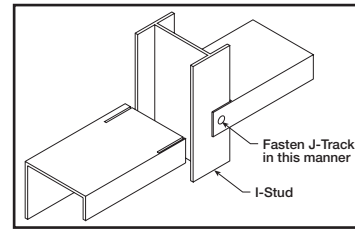
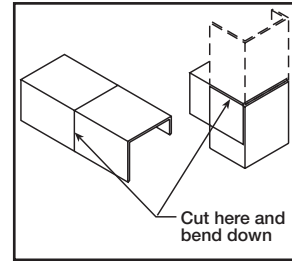

Figure 2: Optional Opening Preparation Detail for I-Stud Assembly



Detail 'A': J-Track to I-Stud Connection



Detail 'B': Forming J-Track

2. Fire damper and sleeve assemblies 80 in. W x 50 in. H (2032 mm x 1270 mm), 50 in. W x 80 in. H (1270 mm x 2032 mm), or 40 in. W x 100 in. H (1016 mm x 2540 mm) and smaller only require retaining angles on one side of the partition (See **Figure 3** and **Figure 4**). Retaining angles must be attached to the sleeve and the partition. Larger damper assemblies require retaining angles on both sides of the partition. Retaining angles must be attached to the sleeve.

- Retaining angles for 1½ hour rated dampers with a width and height 48 in. (1219 mm) or less must be a minimum of 20 ga. (1 mm). Retaining angles for all 3 hour rated dampers and all dampers with a width or height greater than 48 in. (1219 mm) must be a minimum of 16 gauge (1.5 mm). The leg of the retaining angle on the damper sleeve shall be a minimum of 1¼ in. (32 mm). The leg of the retaining angle on the wall/floor shall be long enough to cover the annular space and overlap the wall by at least 1 in. (25 mm).
- Retaining angles must be attached to the partition and sleeve using one of the methods shown below.
- Tack or spot welds
- #10 sheet metal screws and bolts
- Drywall screws of a length such that the screw engages the stud/track by a minimum of ½ in. (13 mm)
- A minimum of two connections per side, top, and bottom, 12 in. on center maximum for openings of 48 in. W x 36 in. H (1219 mm x 914 mm) and less, and 6 in. (152 mm) on center for openings 80 in. W x 50 in. H (2032 mm x 1270 mm), 50 in. W x 80 in. H (1270 mm x 2032 mm), and 40 in. W x 100 in. H (1016 mm x 2540 mm) or less.

Grille Installations (Dampers up to 36 in. x 36 in. [914 mm x 914 mm] maximum)

- Angle legs may be reversed and one leg inserted into the wall opening. Retaining angles used in conjunction with grille installations must be a minimum of 20 gauge (1 mm) steel and have a minimum of ⅝ x 1 in. (16mm x 25 mm) legs (See **Figure 5** and **Figure 6**).

OR

- Using #10 sheet metal screws, screw from inside of sleeve into the studs. Space screws a maximum of 6 in. (152 mm) on center and a maximum of 2 in. (51mm) from the corners (minimum of 2 screws per side). (See **Figure 7** and **Figure 8**).

3. These installation instructions apply to the following wall design numbers as detailed in the UL Fire Resistance Directory: U438, U469, U497,U499, V473 System A.

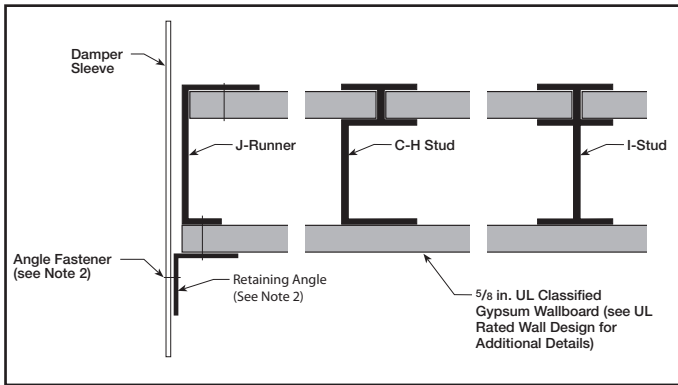

Figure 3: 1 Hour Shaftwall Rating

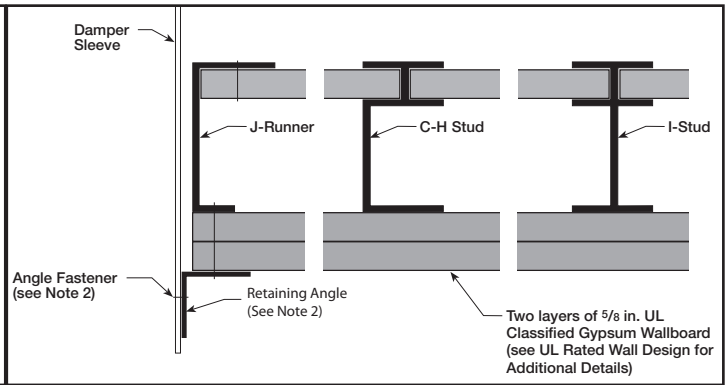

Figure 4: 2 Hour Shaftwall Rating

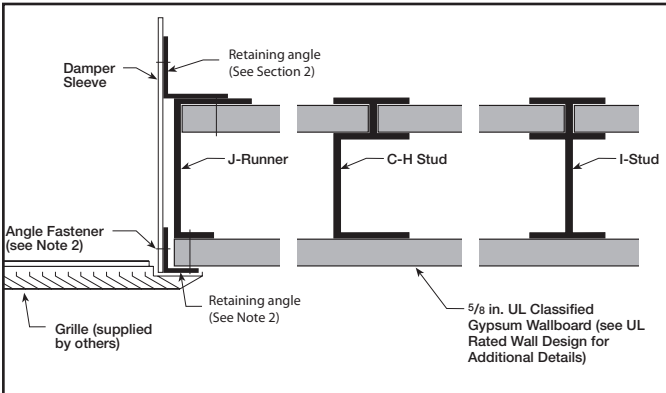

Figure 5: 1 Hour Shaftwall Rating

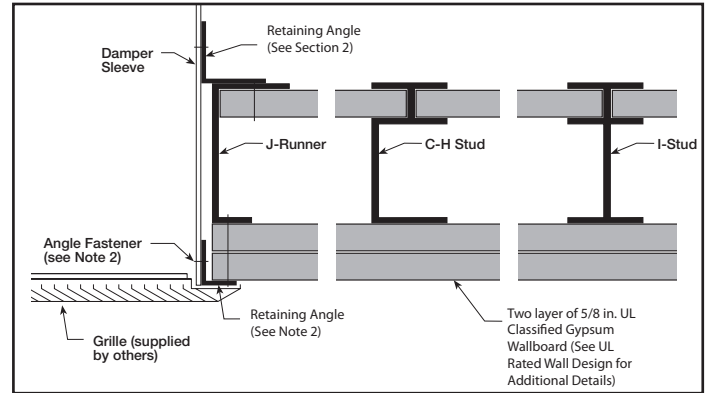

Figure 6: 2 Hour Shaftwall Rating

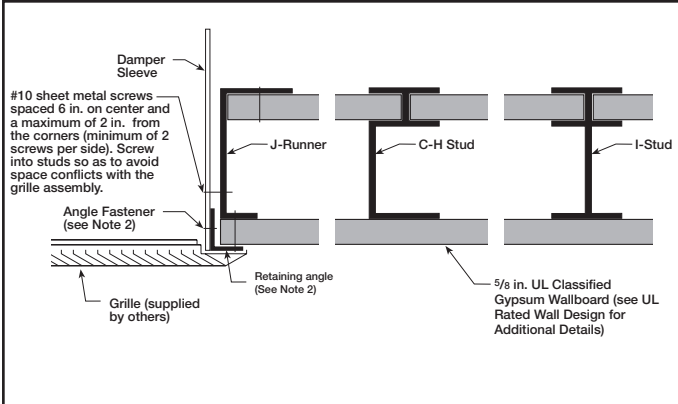

Figure 7: 1 Hour Shaftwall Rating

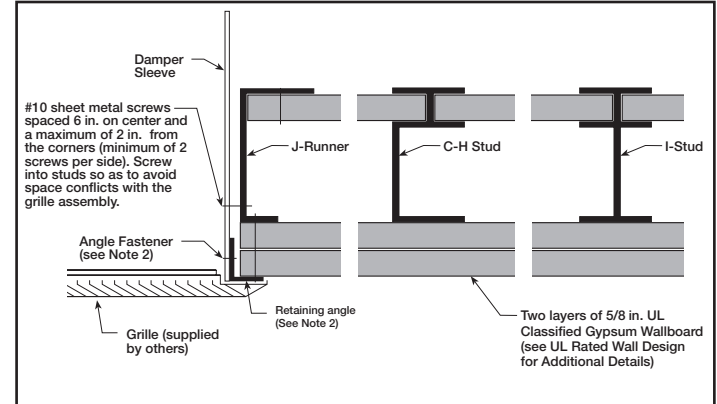

Figure 8: 2 Hour Shaftwall Rating

Our Commitment

As a result of our commitment to continuous improvement, Greenheck reserves the right to change specifications without notice.

Product warranties can be found online at Greenheck.com, either on the specific product page or in the literature section of the website at Greenheck.com/Resources/Library/Literature.

